

DRIVE▶RITE

AIR SUSPENSION SYSTEMS

DR.02.012426 / DR.02.012427

FIAT DUCATO
PEUGEOT BOXER
CITROËN JUMPER / RELAY
X250 / X290 CHASSIS KIT

INSTALLATION INSTRUCTIONS



Table of Contents

Table of Contents	2
Introduction	3
IMPORTANT SAFETY NOTICE.....	3
Special Instructions for Air Connections.....	3
Kit Contents	4
HARDWARE LIST.....	4
Step by Step Installation	5
Step 1: Prepare the Air Spring assembly – Lower Bracket.....	5
Step 2: Prepare the Vehicle	6
Step 3: Mount the Upper Chassis Bracket to the Vehicle.....	7
Step 4: Prepare the Air Spring assembly.....	7
4a: Anti-Roll Bar	8
4b: No Anti-Roll Bar	8
Step 5: Install the Air Spring Assembly to the Chassis	9
Step 6: Air Spring Assembly to Axle	10
6a: Anti-Roll Bar	11
6b: No Anti-Roll Bar	12
Step 7: Brake Line	14
Step 8: Routing the Air Tubing.....	15

Introduction

The purpose of this publication is to assist with the installation of the Drive-Rite Semi-Air air suspension kit.

It is important to read and understand the entire installation guide before beginning installation or performing any maintenance, service or repair. The information here includes a hardware list and step-by-step installation information.

Drive-Rite reserves the right to make changes and improvements to its products and publications at any time. Contact Drive-Rite (see back page) or visit us online at www.driveriteair.com for the latest version of this manual.

IMPORTANT SAFETY NOTICE

The installation of this kit does not alter the Gross Vehicle Weight Rating (GVWR) or payload of the vehicle. Check your vehicle's owner's manual and do not exceed the maximum load listed for your vehicle.

Gross Vehicle Weight Rating = the maximum allowable weight of the fully loaded vehicle (including passengers and cargo). This number — along with other weight limits, as well as tire, rim size and inflation pressure data — is shown on the vehicle's Safety Compliance Certification Label.

Payload: The combined, maximum allowable weight of cargo and passengers that the truck is designed to carry. Payload is GVWR minus the Base Curb Weight.

Precautions

Never exceed the maximum and minimum recommended pressure limits:

- Minimum Pressure 1 Bar (14.5 p.s.i.)
- Maximum Pressure 7 Bar (100 p.s.i.)

While it is possible to inflate the system in static mode to 7 Bar (100 p.s.i.), it should not be necessary to exceed operating pressure in the region of 3.5 Bar (50 p.s.i.) at vehicle full GVW. This kit should not be used to carry any greater load than manufacturers stated GVW.

To avoid damage to air springs – When the kit has been installed, please ensure there is adequate clearance (25mm) around the air spring so the air spring does not come in contact with any other parts.

NEVER DRIVE WITH DEFLATED AIRSPRINGS

Special Instructions for Air Connections



- To cut the tubing correctly an appropriate cutter must be used (not scissors)



- When inserting the tubing into the connection, it must be pushed in approximately 14mm until a 'click' is heard.
- To remove the tube, you must push the flange in on the connection and at the same time pull the tube. (No tool is necessary.)
- **ATTENTION**, when a tube is removed it is important to trim 14mm from the end before reconnection.
- It is advisable that LOCTITE or similar sealant be used on the threaded fittings.

Kit Contents

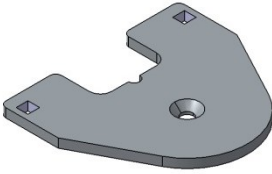
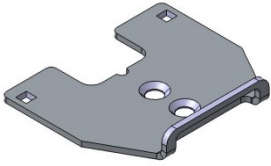
▼ HARDWARE LIST

Name	Quantity	Picture/Description	Part #
Upper Chassis Bracket	2		DRV-7511
Upper Air Spring Bracket	2		DRV-7510
Lower air Spring Bracket	2		DRV-7509
Airspring	2	Style 26 Metric Air Spring 2426 kit	6693
Airspring	2	Style 267 Metric Air Spring 2427 kit	6694
Air Tubing	5m	6mm tubing	1364-1MR
Thermal Sleeve	2		0899
Nylon Tie Strap	15	Cable Ties	9037
M10x1.5x30 Coach Bolt	4	Upper chassis brkt to air spring brkt	3900
M10 Nyloc Nut	4	For M10x1.5x30mm bolts	0034
M10 Flat washer	8	For M10x1.5x30mm bolts For M10x1.5x20mm bolts	0079
M10x1.25-30 Countersunk Bolt	2	Upper Bracket to Chassis	2530
M14 Nyloc Nuts	8	U-Bolt nut replacements	3847
M14 Flat Washer	8	For U-bolts	0134
M10x1.5x20 Hex Head Bolt	4	Air Spring to Lower Bracket	3813
M10x1.5x20 Countersunk Bolt	4	Air Spring to Upper Bracket	3845
1/4" to 6mm Elbow Fitting	2		3614
6mm Inflation Valve	2	PTC or Compression	3660/3151
6mm T-Piece	1		3666
Compression Joiner	2		DR.41.010190

Step by Step Installation

Step 1: Prepare the Air Spring assembly – Lower Bracket

Install the swivel elbow in the air inlet hole on the top plate of the air springs.

It is recommended that a sealant is used when attaching the elbow.



Fasten the Air Spring to the Lower Bracket. Use the M10x1.5-20mm Hex bolts and washers provided. (Torque to approx. 38Nm).



↘ Step 2: Prepare the Vehicle

The vehicle is equipped with a rubber bump stop which is positioned on the frame directly above the axle. Remove this bump stop together with the metal bump stop cup and discard.



Please note that some bump stop cups will need to be rotated out of position.

This hole will be used to secure the Upper Chassis Bracket into position



↘ Step 3: Mount the Upper Chassis Bracket to the Vehicle

Mount the Upper Chassis Bracket onto the vehicle using the fine thread M10x1.25-30mm countersunk bolt provided.

(Torque to approx. 50Nm)

Ensure that it is sitting flat against the chassis.



↘ Step 4: Prepare the Air Spring assembly

For vehicles fitted with an anti-roll, the air spring assembly needs to be turned to allow it to be mounted inboard.

The pictures on the right show how the anti-roll bar is in close proximity to the air spring.

If the assembly is in such close proximity this means it will have to be mounted differently.



↘ 4a: Anti-Roll Bar

If an anti-roll bar is present on the vehicle the Upper Air spring Bracket should be mounted to the airspring as per the picture.

Torque to approx. 50N.m



↘ 4b: No Anti-Roll Bar

If there is no anti-roll bar present on the vehicle the air spring should be mounted to the Upper Air Spring Bracket as per the picture.

Torque to approx. 50N.m



Step 5: Install the Air Spring Assembly to the Chassis

Place the air spring assembly into position on the Leaf Springs.

The 'bend' in Upper Air Spring Bracket sits onto the flange on the chassis.

It may be easier to rotate the bracket into position as seen in the image.

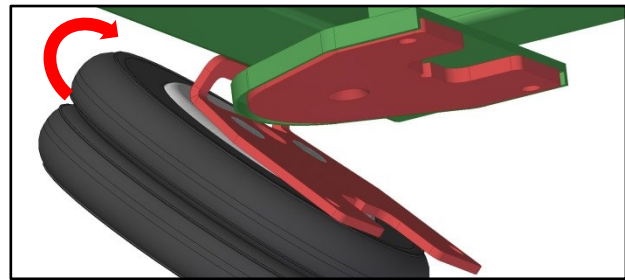

Bolt the upper air spring bracket to the Upper Chassis Bracket with the M10x1.5-30mm coach bolts, flat washers and nyloc nuts provided.

(Torque to approx. 38Nm).



Step 6: Air Spring Assembly to Axle

Remove the U-Bolts from the vehicle's axle. Retain U-Bolts for re use and discard the M14 nuts.

The Lower Bracket must sit under the U-bolts.

Remove the M14 nuts holding the U-Bolts and discard the nuts. The U-Bolts will be used with new nyloc nuts.

Remove and discard the original saddle piece.



Position the assembly on top of the leaf and install the new saddle between the U-Bolts.

Ensure that the U-Bolts are sitting correctly over the lower bracket.

Use the supplied M14 Nyloc nuts to tighten the U-bolts back into place.

(Torque to approx. 130Nm).

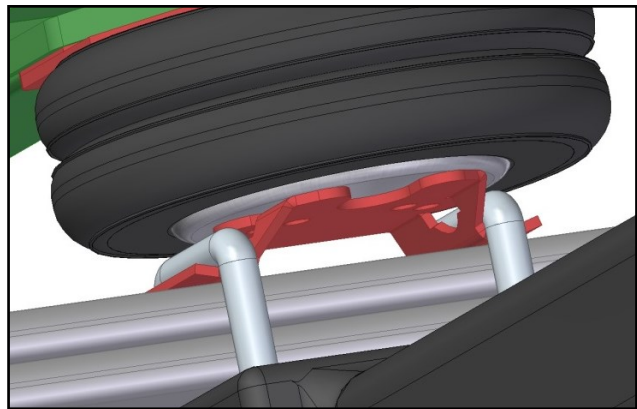

6a: Anti-Roll Bar

If the vehicle is fitted with an anti-roll bar, the air spring should be mounted to the Upper Bracket as per - *Step 4a: Anti-Roll Bar*.

Replace the U –Bolts and secure in place using M14 nyloc nuts provided.

The lower bracket is mounted on the leaf spring with the tabs facing inboard.

Torque U-Bolts to approx. 140Nm

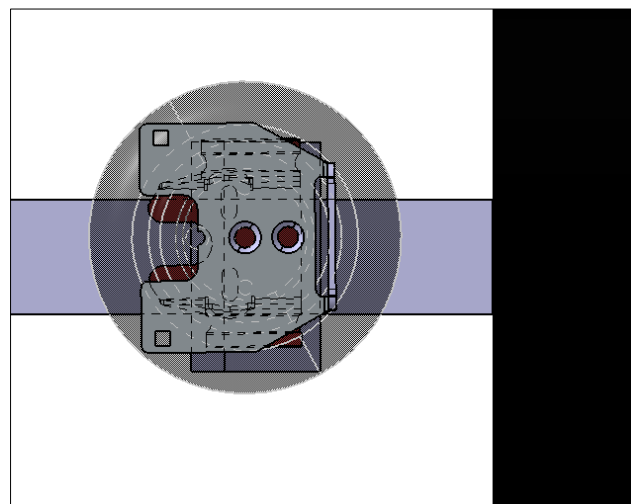
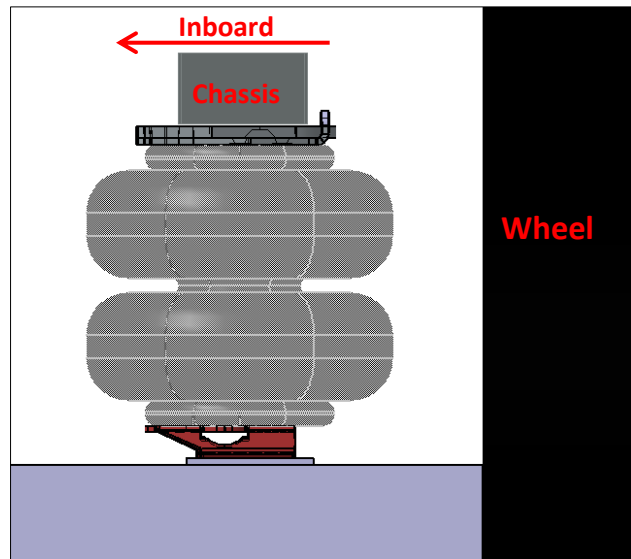

6b: No Anti-Roll Bar

If the vehicle is fitted with an anti-roll bar, the air spring should be mounted to the Upper Bracket as per - *Step 4b: No Anti-Roll Bar*.

Replace the U –Bolts and secure in place using M14 Nyloc Nuts provided.

The lower bracket is mounted on the leaf spring with the tabs facing outboard.

Torque U-Bolts to approx. 140Nm

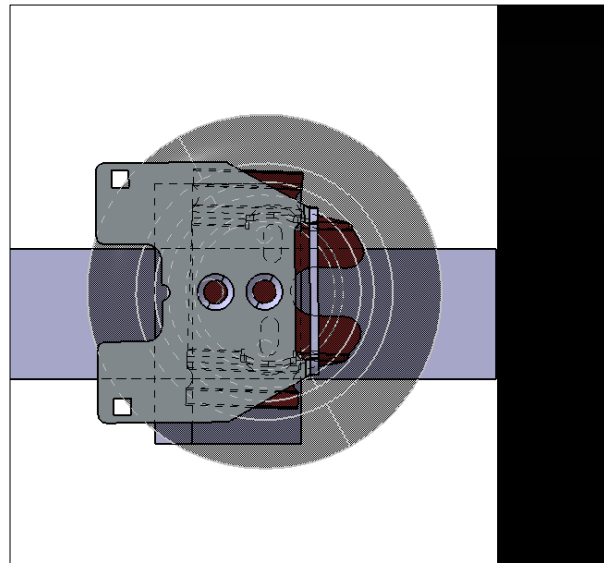
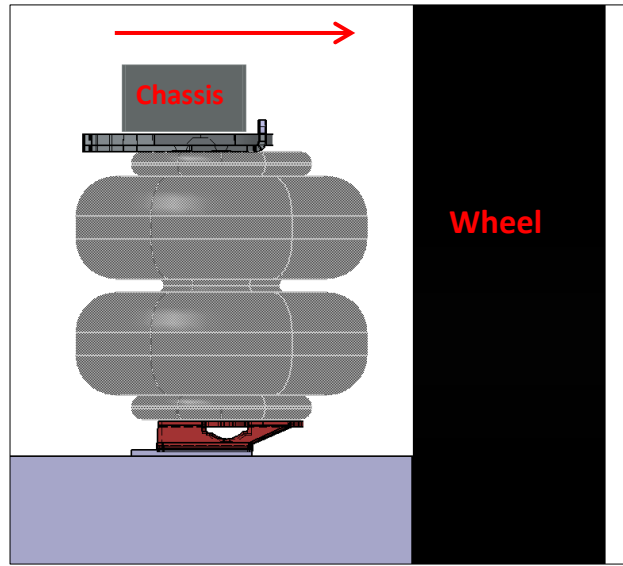

Please ensure that there is an equal amount of thread showing before and after using the torque wrench

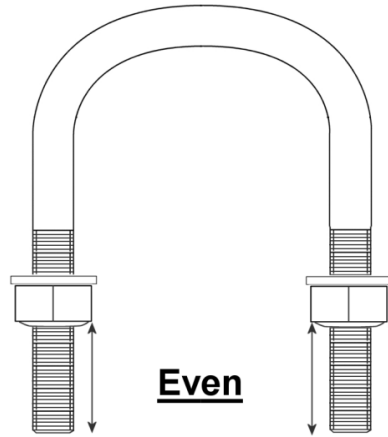
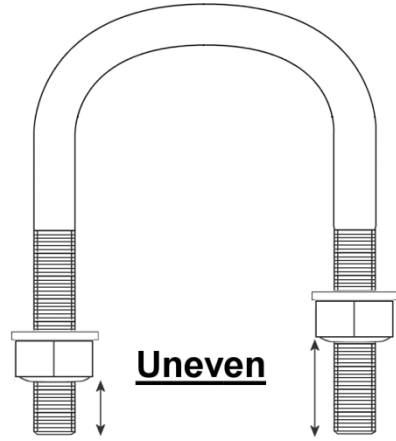

↘ Step 7: Brake Line

In some versions of this vehicle there is a brake sensor bracket present.

- a) This bracket will need to be bent to ensure it sits above the top line of air spring top plate (**red line**).
- b) You will need to re-secure sensor cables & ensure no risk of cable damage during vehicle movement.
- c) Bending this bracket is required to stop risk of damaging air spring during use.
- d) If you do not wish to bend brackets, an additional air spring spacer kit is available. (DR.08.014637)

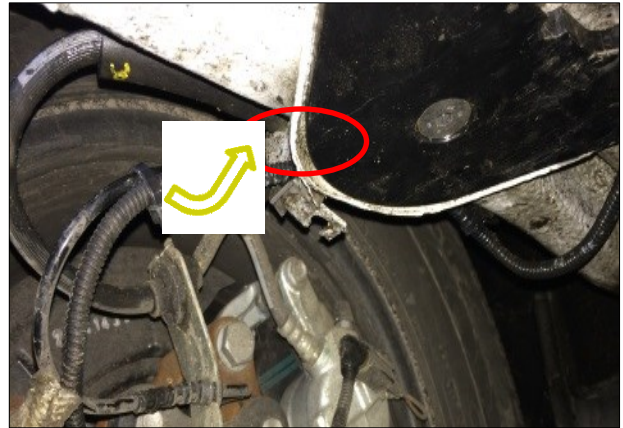

Bracket sit above red line

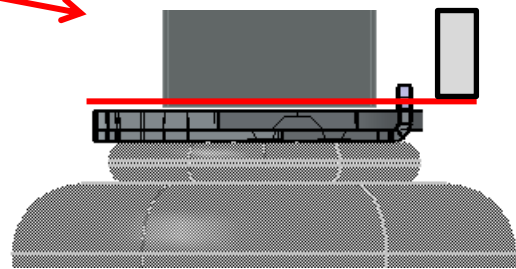

Step 8: Routing the Air Tubing

Cut a long length of tubing in order to connect the valve to the nearest air spring. Do the same for the opposite side. Choose whether you want separate inflation valves for each side or one valve common to both sides using the T shaped connector. Use the nylon ties provided to tie the tubing up into a safe position.

Note: Inflation valves may be Push-to-Connect type or compression-type.



When cutting the air tube, it is vital that the tube is not cut at an angle. This could cause an air leak. It is recommended that a tube cutter or a sharp blade.



Drill an 8mm (5/16") hole and mount the inflation valve as shown in the diagram, pushing the valve through the hole from behind and attaching with 2 washers and a nut.

Cut the air tube to length, making sure the end is cut squarely, and push the end as far as possible into the back of the inflation valve.

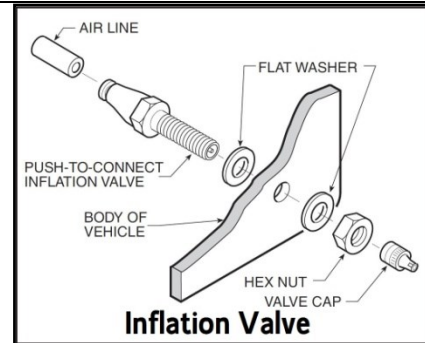

IMPORTANT:

- Attach all tubing securely to the underneath of the vehicle using nylon ties.
- Do not attach to brake lines.
- Protect the tube with the sleeves provided where there are any sharp edges or sources of heat.
- Ensure that all fittings are correctly torqued.

Examination:

After assembly, inflate air springs and check all mounting bolts are tight. Screw all connections tight again. It must be ensured that the mounting brackets cannot move. If the plates touch the brake hose at the air springs, then these must be moved by suitable means.

Teilgutachten / Test report
 Nr. / No. 8112359101 vom / of 01.06.2015
 TGA-Art 8.3

IFM - Institut für Fahrzeugtechnik und Mobilität

TUV NORD Mobilität

Art der Umrüstung / Modification : Zusatzluftfedersystem / Semi-Air suspension system
 Teiltyp / Type of part : DR.02.012426
 Hersteller / Manufacturer : Drive-Rite Ltd., Ballycoolin, Dublin 15, Irland

über die Vorschriftenmäßigkeit eines Fahrzeuges bei bestimmungsgemäßem Ein- oder Anbau von Fahrzeugteilen gemäß § 19 (3) Nr. 4 StVZO
 on the compliance of a vehicle when vehicle parts are properly installed and fitted to the vehicle in accordance with § 19 Par. 3 No. 4 StVZO (German Road Traffic Safety Code)

Änderungsumfang : Zusatzluftfedersystem
 Modification : Semi-Air suspension system
 Teiltyp / Type of part : DR.02.012426
 Hersteller / Manufacturer :

DRIVE-RITE
 AIR SUSPENSION SYSTEMS

Drive-Rite Ltd.
 Unit 626 Kilshane Avenue
 North West Business Park
 Ballycoolin, Dublin 15
 Irland

SÜD Auto Service GmbH
 estendstraße 199
 J-80686 München



Prüfbericht Nr. / Test Report No.: 11-00595-CX-GBM-04
 Hersteller / Manufacturer: DRIVERITE Ltd.
 Typ / Type: DR.02.0124... Seite / Page 1 von/of 17

TEILEGUTACHTEN
 Nr. 11-00595-CX-GBM-04
 TGA-Art: 8.1

über die Vorschriftenmäßigkeit eines Fahrzeuges bei bestimmungsgemäßem Ein- oder Anbau von Teilen gemäß § 19 Abs. 3 Nr. 4 StVZO

für das Teil / den Änderungsumfang : Zusatz-Luftfedersystem an Achse 2
 vom Typ : DR.02.0124...

Ausführungen: DR.02.012110...
 DR.02.012426...
 DR.02.012427...
 DR.02.012428...
 DR.02.012429...

des Herstellers : DRIVERITE Ltd.
 Unit 626 Kilshane Avenue, North West Business Park
 Ballycoolin
 IRL - 15 Dublin

für das Fahrzeug : Fiat Ducato / Citroen Jumper / Peugeot Boxer
 Sowie vervollständigte Fahrzeuge weiterer Fa



VCA, 1 Eastgate Office Centre,
 Eastgate Road, Bristol, BS5 6XX, United Kingdom
 enquiries@vca.gov.uk | www.dtt.gov.uk/vca | +44(0)1179515151

Report Number: VSQ314886

Revision: 0

**Test Report:
 Special Requirements for Vehicles Equipped with
 Vehicle Stability Function**

Legislation

Directive 2007/46/EC as amended by Regulation (EU) 214/2014
 Annex XI, Appendix 1 / 3, Item 9B
 UNECE Regulation 13.11 to Supplement 10

Test Details

Location of Test : VCA Midlands Centre, using MIRA Limited facilities
 Nuneaton, Warwickshire, CV10 0JA
 Date of Test: 03 December 2014 – 19 January 2015
 VCA Representative(s): S. Fraser
 Manufacturer's Representative(s): Sharon Meyler and Dan Levy
 Reason for Test Report: Test report only to cover vehicles with mass in running order
 >1735 kg

Manufacturer Details

Name and Address: Drive-rite Ltd., Unit 626 Kilshane Avenue, North West
 Business Park, Ballycoolin, Dublin 15, IRELAND
 X250 and X290
 Type:
 Commercial Description: Fiat Ducato, Peugeot Boxer, Citroen Jumper/Relay
 Category: M1 and N1

Conclusion

The above mentioned vehicle was tested in accordance with the above mentioned legislation w
 found to comply in all respects.



Full Certificates Available, contact Drive-Rite for details

DRIVE-RITE

AIR SUSPENSION SYSTEMS



Unit 626 Kilshane Avenue, North West Business Park, Ballycoolin, Dublin 15, Ireland
 Telephone: +353 1 8612 632 Fax: +353 1 8612 647 email: info@driveriteair.com
 Web: www.driveriteair.com